



Officina Meccanica

**PIETRO RAMELLA & C. s.a.s**

Carding sets and carding machines producers since 1947

Via S.M. di Campagnate, 14

13900 - BIELLA (BI) - ITALY

tel. +39-015-401755 fax +39-015-8492807

www.ramellapietro.com e-mail ramella@ramellapietro.com

## **MODEL SYNT CV2P w.w. 3000 mm**

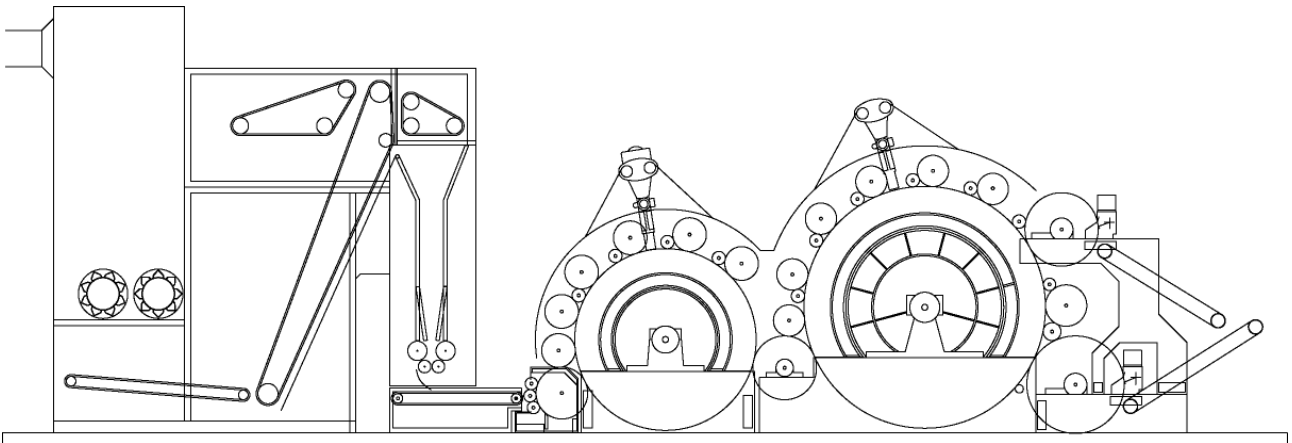

### **Technical description and machine composition :**

- Silo for the automatic card feeding
- Automatic volumetrical feeder
- Inlet unit
- Breast
- First unit
- Fly combs and belt conveyors

## SILO FOR THE AUTOMATIC CARD FEEDING

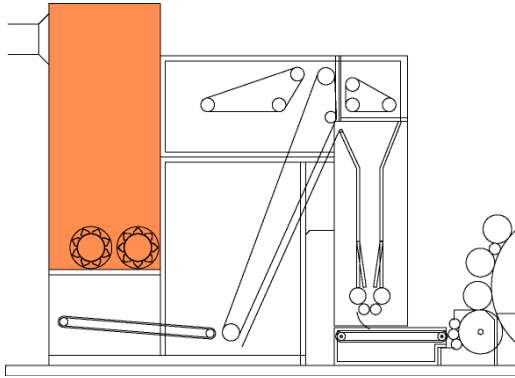

The silo receives the raw material from pipes coming from the blending plant (pipes are excluded from our quotation) and feeds the automatic volumetric feeder. It's provided with two photoelectric cells setting the minimum and maximum level. The silo unload is done by two cylinders driven by two motoreducers. A photoelectric cell, placed on the mixing table, controls unloader cylinders start and stop. Silo is provided with a door with inspection windows.

## AUTOMATIC VOLUMETRIC FEEDER

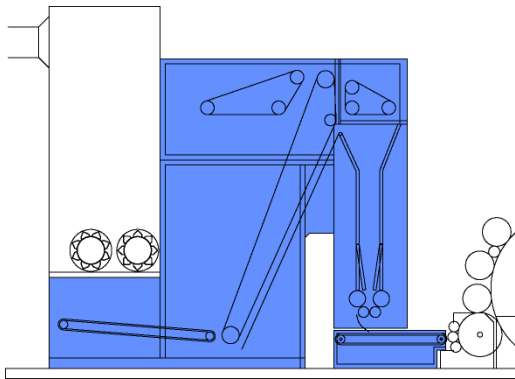

The volumetric feeder is made of steel sheets. The feeder is provided with 6 tables:

- Pinned table, dosing table and unloader table with outer mantle in PVC, slats of multi-layer plywood and pins of tempered steel.
- Mixing table, feeding table and press mixture table with outer mantle in PVC and slats of multi-layer plywood.

The feeder is provided with the dosing table: it's possible to change the quantity of material loaded bringing it near or moving it away from the pinned table.

The unloader table discharge the material from the pinned table.

The dosing and the unloader tables pins are projected to opportunely dose the material and to obtain its complete unload.

The material containing walls in the dosing are in inox steel: one wall is fixed and the other is movable so it's possible to increase or reduce the volume sent to the inlet unit.

A series of photoelectric cells, placed on the feeder walls, maintains the material at the same level.

The photoelectric cells modify the feeding speed and so it's possible keep a constant material level in the silo independently to the fibre processed and exit speed.

All driving parts are assembled on first class ball bearings.

The reduction cases with cog-wheels are in oil bath and hermetically closed.

## INLET UNIT

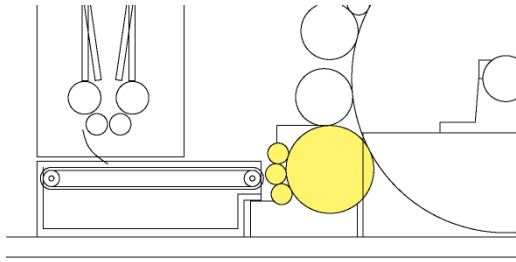

composed of :

N. 1	Upper taker-in roller	∅ 100 mm	Rigid card clothing
N. 1	Under taker-in roller	∅ 100 mm	Rigid card clothing
N. 1	Cleaner roller	∅ 100 mm	Rigid card clothing
N. 1	Opener roller	∅ 420 mm	Rigid card clothing

The inlet unit introduces the material in the breast in a regular way, avoiding, through safety devices, the foreign bodies entry into the process.

All rollers are wired with rigid card clothing saw tooth type.

The opener roller rotates toward the lower and it's provided with a knife with a nails puller knife that eliminates the foreign bodies among the fibers.

The opener roller is provided with a first class safety device that stops the machine in case of foreign bodies get into the processing.

The inlet unit is driven by an independent AC motor and the speed can be easily changed from the main electrical board

## BREAST

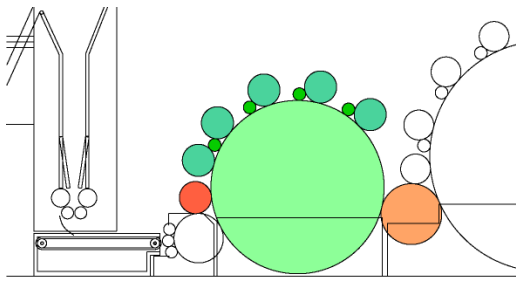

Composed of:

N. 1	Drum	∅ 1500 mm	Rigid card clothing
N. 5	Worker rollers	∅ 250 mm	Rigid card clothing
N. 4	Cleaner rollers	∅ 100 mm	Rigid card clothing
N. 1	Knot breaker roller	∅ 250 mm	Rigid card clothing
N. 1	Conveyor roller	∅ 520 mm	Rigid card clothing

The breast opens the fibres entering in process in tangled way and prepares it to the following passage. The conveyor roller connects the breast to the first unit.

All rollers are wired with rigid card clothing saw tooth type.  
This unit is clothed with rough card clothing to give a first opening to the material.

The frame is made of double steel sheet .  
Crescents are manufactured in a single piece of cast iron, they are turned externally for the right fitting with covers.

## FIRST UNIT

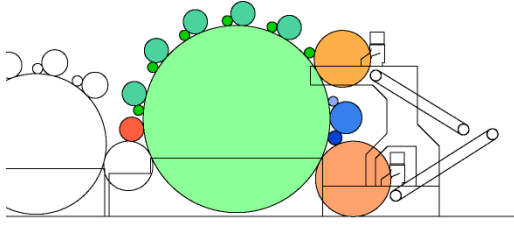

Composed of:

N. 1	Drum	∅ 2000 mm	Rigid card clothing
N. 5	Worker rollers	∅ 250 mm	Rigid card clothing
N. 6	Cleaner rollers	∅ 112 mm	Rigid card clothing
N. 1	Fancy roller	∅ 300 mm	Flexible card clothing
N. 1	Under fancy roller	∅ 114 mm	Rigid card clothing
N. 1	Upper fancy roller	∅ 90 mm	Rigid card clothing
N. 2	Doffer rollers	∅ 700 mm	Rigid card clothing

The first unit completes the fibres parallelizing already partially done by the breast.  
The fancy roller permits a better material removal by the second doffer roller.  
Two doffer rollers allow high productivity and a great quality of the final product

The fancy roller is clothed with a flexible card clothing placed on a web with rubber bottom.  
All other cylinders are wired with rigid card clothing saw tooth type.  
The fancy roller and all worker rollers are made of light aluminum alloy.  
All other cylinders are made of steel.

## FLY COMBS AND BELT CONVEYORS

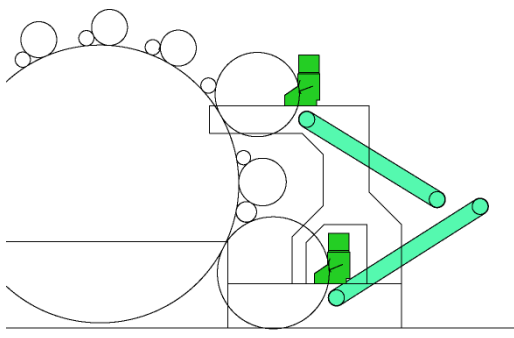

The fly combs detach the web from doffer rollers, then the belt conveyors transport it to the following unit.  
The webs union permits a better regularity of the final product.

The fly comb moves at high speed with a 40 mm oscillation.

## TECHNICAL DETAILS

This carding machine is equipped by 19 AC motors. These motors drive independently:

- Fixed cylinder of the silo
- Movable cylinder of the silo
- Pinned table and mixing table (variable speed motor)
- Dosing table
- Unloader table (variable speed motor)
- Movable panel of the volumetric feeder
- Feeding table, press-mixture table and inlet unit (variable speed motor)
- Breast drum, cleaner rollers, knot-breaker roller (variable speed motor)
- Breast worker rollers (variable speed motor)
- First unit drum, cleaner rollers, fancy roller, under fancy roller, upper fancy roller (variable speed motor)
- First unit worker rollers (variable speed motor)
- First offer roller, first conveyor belt (variable speed motor)
- Second offer roller, second conveyor belt (variable speed motor)
- Fly combs (2 motors)
- Protection covers (4 motoreducers)

The variable speed motors can be easily controlled by the main electric panel.

All rotary parts are assembled on first-class ball bearing.

Main cylinders and doffers are made in steel sheet heat treated into an electric furnace.

## ELECTRIC PANEL

The panel is provided with user-friendly devices to control all motor speed.

An electrical stabilizer provide the right power supply to all electrical parts.

The panel is also provided with a display to control the main machine functions and an acoustic alarm that rings in case of :

- signal of the inlet unit safety device.
- signal of can-coiler filling

## FRAME

The frame is fully manufactured in our factory in steel sheet and it is heat treated in special electric furnace. It is made of double steel sheet with internal strengthening that completely eliminates the vibrations.

Crescents are manufactured in a single piece of cast iron, they are turned externally for the right fitting with covers.

## PROTECTION SYSTEMS AND QUALITY CERTIFICATION

Both sides of the machine are completely protected by security doors according to the current rules. The lock device doesn't allow open the lateral protections while the machine is running. This will be deactivated only when the machine is completely stopped and if all protection doors are closed.

Covers protect the upper side of the machine: they are in steel sheets with aluminum rims and they are provided with electric lift device and automatic blockage system. The blockage system is deactivated only when the carding machine is completely stopped.

The machine is marked C.E. and follows UNI EN ISO 9002 rules.